

BUX NEO-EP

Electro permanent lifting magnets
Safe, user and environment friendly



Features and benefits:

- suitable for both round and flat material
- available in lifting capacities between 125 and 1000 kg
- energized by a current surge
- zero energy consumption following activation
- magnetic force remains intact if main power fails
- maintains high holding force on rough or uneven surfaces
- effortless working practice thanks to push button operation
- optional remote push button station
- can be interfaced with robot control
- low maintenance, no moving parts



BUX NEO-EP

The range of BUX NEO-EP lifting magnets allow easy handling of flat and cylindrical loads up to 1000 kg. They offer a high degree of safety as the holding force is ensured by powerful permanent, high energy magnets which keep “pushing” even when the contact between magnet and load is poor. The NEO-EP magnets are supplied with an operating instruction and CE-declaration of conformity.

Applications

- Load, unload machine tools
- Handling and transport of materials in storage rooms
- Lifting of medium sized structures in assembly and fabrication
- Repetitive handing in automated systems

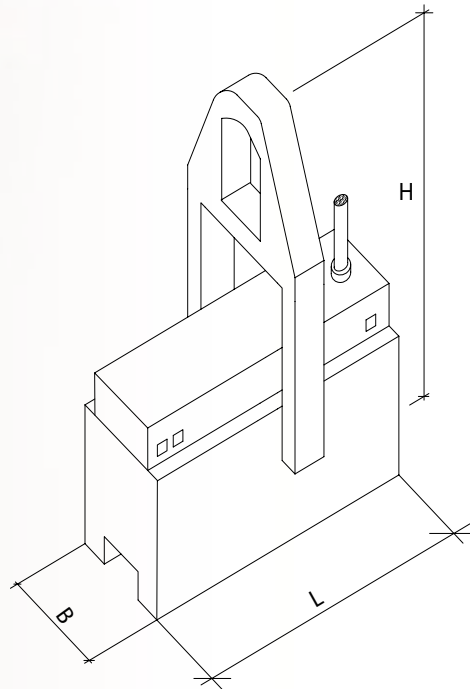

Technical Specifications

Model		NEO-EP 125	NEO-EP 250	NEO-EP 500	NEO-EP 1000
Workloadlimit (WLL)* - flat material	kg	125	250	500	1000
- round material	kg	65	125	250	500
Tested break-away force*	daN	400	800	1600	3100
Length x Width	mm	210 x 65	270 x 125	370 x 125/167	445 x 125/167
Height to hook	mm	170	350	425	425
Mass	kg	13	40	54	70
Input voltage	VAC	230	230	230	230
Current consumption	A	2,5	4,7	6,7	8

* Tested on a ground, 50 mm thick, mild steel plate

* Nominal WLL includes a safety factor of at least 3

Real WLL varies with workpiece material, thickness and surface quality.