

PRÄZISIONSSCHRAUBSTÖCKEN

REF 40.09

# Sinus-Schraubstock Typ EMPSS

Schleifen Erodieren (EDM) Messen

- Aus gehärtetem Werkzeugstahl und präzisionsgeschliffen
- Härte HRC60
- Schwenkung in zwei Achsen
- Horizontale Rotation 360°
- Max. Winkel 45°
- Mit Beschriftung

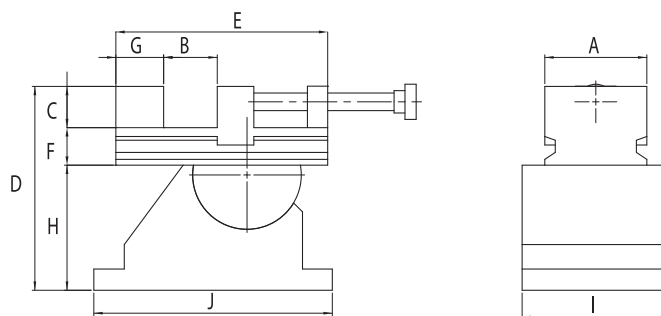
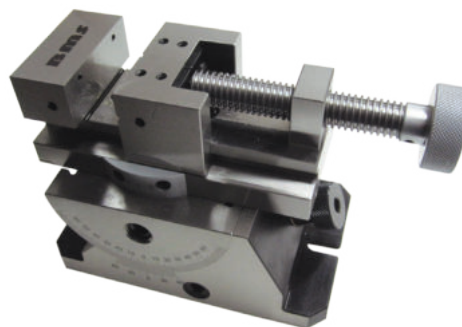

Referenz	Gewicht in Kg	A	B	C	D	E	F	G	H	I	J
40.09.70	14,0	70	0-80	30	137	160	32	33	75	110	178



robuste Konstruktion / Sicher / effektiv



REF 40.09.ER



REF 40.09.SC03



REF 40.09.SC04

PRÄZISIONS-GERÄTE